

# LiquiCount

## LC1 User Manual V3



# LC1 V3 Manual

Date: 19 February 2026

Manufacturer: LiquiCount Ltd

LiquiCount Ltd, Rickmansworth, Hertfordshire, UK

Website: <https://liquicount.co.uk>

Email: [enquiries@liquicount.co.uk](mailto:enquiries@liquicount.co.uk)

Company No: 16461165 © LiquiCount Ltd 2026



## ATTENTION

Before connecting any sensors, ensure that the correct sensor supply voltage is selected. Using a 5v supply is only suitable for sensors designed to operate at 5v; connecting a 24v sensor to a 5v supply will result in the sensor not functioning. Selecting a 12–24v supply for a 5 V sensor can cause permanent damage to the sensor. Only sensors rated for 12–24v must be used when the 12–24v supply option is selected. Failure to follow these guidelines may result in equipment damage or incorrect operation.



See '7.7 Setting Sensor Voltages (SENSOR VOLTAGE)' on page 13 to understand how the sensor voltages are set.

**For safety, the default sensor supply voltage is set to 5 V.**

**The enclosure is designed for normal industrial handling. Do not subject the device to excessive mechanical shock or impact.**

## Contents

---

1. Installation Instructions	4
2. Sensor Wiring	6
3. Wiring Diagram	7
4. Overview	8
5. Technical Summary	9
6. Capabilities	10
7. User Operation	11
7.1 Startup Procedure	11
7.2 Resetting Counts	11
7.3 Access to Settings Menu	12
7.4 Main Menu Options	13
7.5 Calibration (CALIBRATE)	13
7.6 How to Calibrate	14
7.7 Setting Sensor Voltages (SENSOR VOLTAGE)	14
7.8 Test Pulses (GENERATE PULSES)	15
7.9 Edit Labels (EDIT LABELS)	16
7.10 Select Units to Display (UNITS)	17
7.11 Accrued Totals	18
7.12 Exit Menu (Return to Home Screen)	19
8. Safety Information	20
8.1 Intended Use	20
8.2 Electrical Safety	20
8.3 Installation Requirements	20
8.4 Mechanical Safety	21
8.5 EMC Considerations	21
8.6 FCC Compliance (United States)	22
8.6 ICES Compliance (Canada)	23
9. RoHS Declaration	23
10. Regulatory Compliance	23
11. Measuring Instruments Directive (MID)	24
12. Electrical & Environmental Classification	24

## 1. Installation Instructions

The LC1 is designed for panel mounting in a 92 mm × 92 mm cut-out.

1. Mark and cut a 92 mm × 92 mm square opening in the panel using the supplied template, then using the LC1, mark the four mounting hole positions.
2. Drill 4 × 2.5 mm fixing holes.
3. Tap the holes to M3 thread.
4. Secure the unit using the supplied M3 dome-headed bolts, with spring and flat washers.

Alternatively, the unit may be secured using the supplied self-tapping screws, with spring and flat washers.

⚠ Do not over-tighten the fixing screws. Excessive torque may damage the enclosure.

### Wiring

For existing installations where a counter is being replaced, there will be an existing pulse generation device for each channel. Download the relevant replacement instructions for that machine from our website, <https://liquicount.co.uk/Support>

- If one or either of the pumping systems uses a positive displacement pump, the sensor will likely be a proximity switch. It will be mounted near the pump to detect the 'fingers' of a target mounted between the drive motor and the pump. This can be a PNP or NPN proximity switch,.

See Sensor Wiring' on rear of page for details.

- If the pumping system uses a centrifugal pump, there will likely be a flow turbine (for example a Rotor flow sensor). Wire this as shown in the sensor wiring section.

NOTE: The sensor voltage may be listed as 5v-24v Max. in this case, set the sensor voltage to 5v as described in the Setting Sensor Voltage section of the user manual. (<https://liquicount.co.uk/User-Manual/>)

- For new installations where there are no existing sensors, pulse devices will be required. If help is required with flow sensors, please contact LiquiCount for help [enquiries@liquicount.co.uk](mailto:enquiries@liquicount.co.uk)

In cases where the counter may need to be removed in the future from the front without disturbing the panel, the supplied extension harness allows for this.

Wire the enclosed wiring harness extension into the installation, connecting it to the vehicle harness as required, the harness wires are all numbered as per the terminals on the LC1. The number of wires actually used will depend on the installation itself and in some cases, you may prefer to remove the plug from extension harness and wire it directly to the vehicle. If the extension harness is used, any individual wires which are NOT used should be removed from the LC1 terminal block. Do NOT rely on the glue spot on the cable

to insulate the end of the wire, this is only there to keep the cable numbers in place during transportation.

To wire the plug directly to the vehicle, use crimp ferules on the ends of the wires and be careful not to allow any stray strands of wire to link adjacent terminal blocks.

## 2. Sensor Wiring

The counter requires positive input pulses from PNP proximity switches or similar.

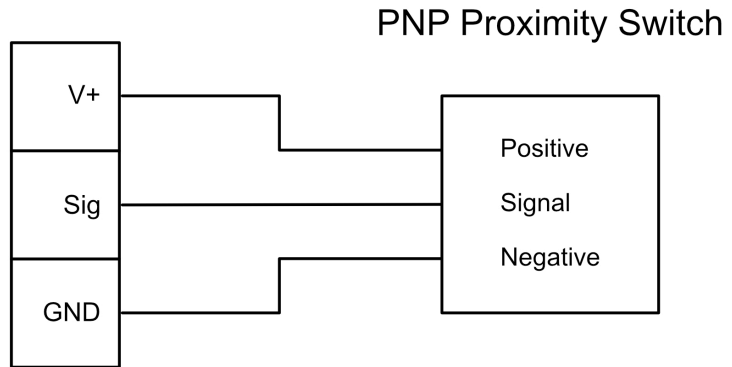

If using an NPN (negative pulse) sensor, a 1k ohm 0.5W pull-up resistor is required between V+ and signal (Sig) on the LC1.

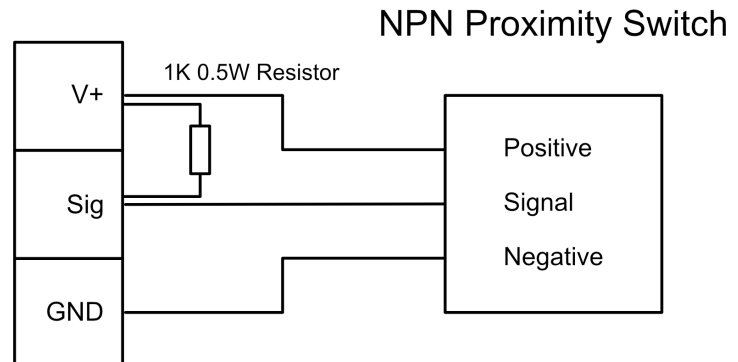

If using a 2 wire proximity switch, a 1k ohm 0.5W pull-up resistor is required between V+ and signal (Sig) on the LC1.

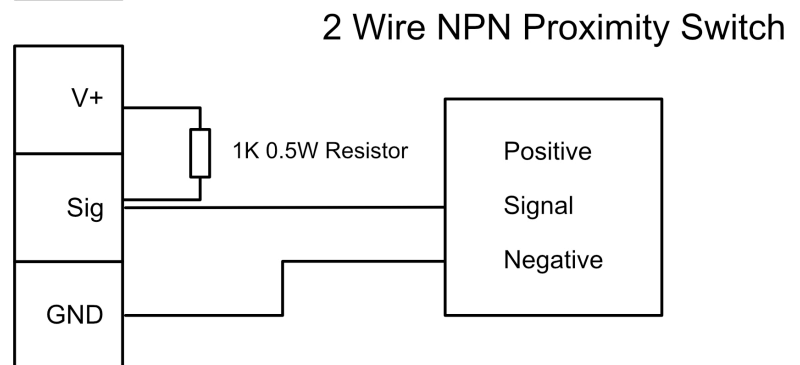

Common colours

- Brown +
- Blue GND
- Black Sig

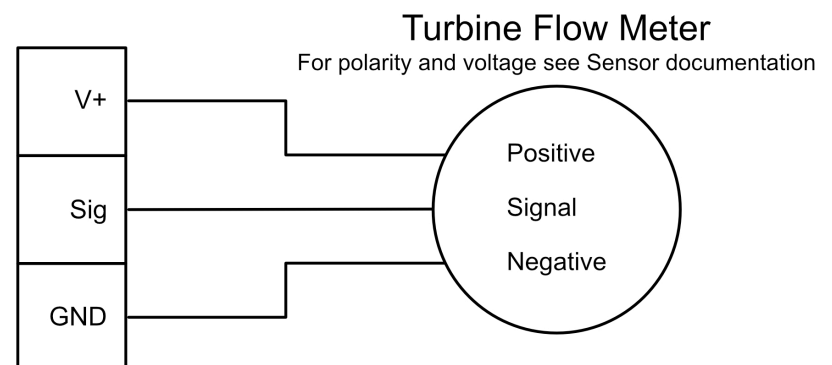

### 3. Wiring Diagram

The device must only be powered from a 12–28V DC SELV (Safety Extra Low Voltage) supply.

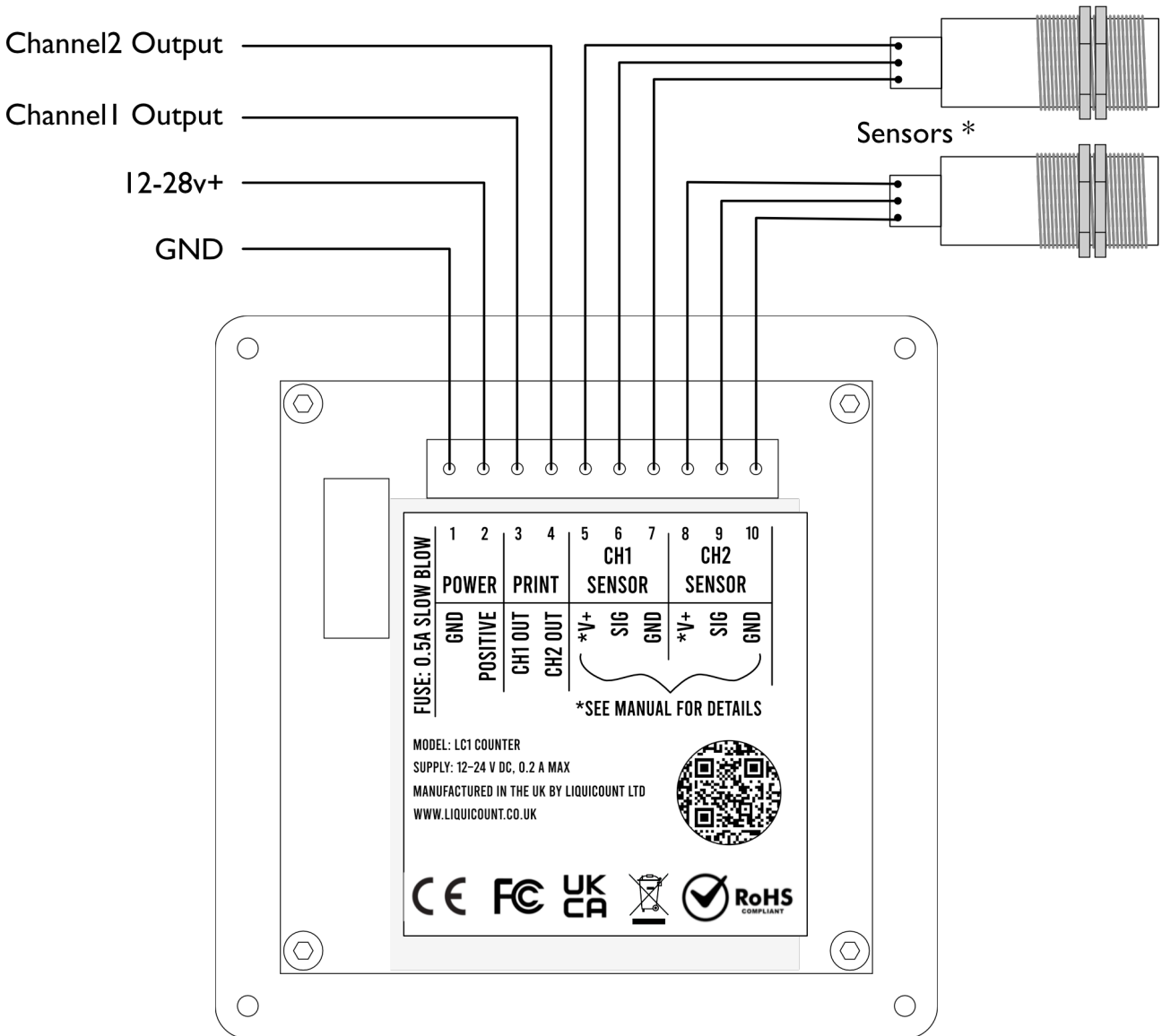

## 4. Overview

The LiquiCount LC1 is a dual-channel, liquid counter designed for precise measurement and logging of two separate liquid or item streams. It features a user-friendly LCD interface, button-based navigation, EEPROM-backed configuration, and pulse outputs for external devices.

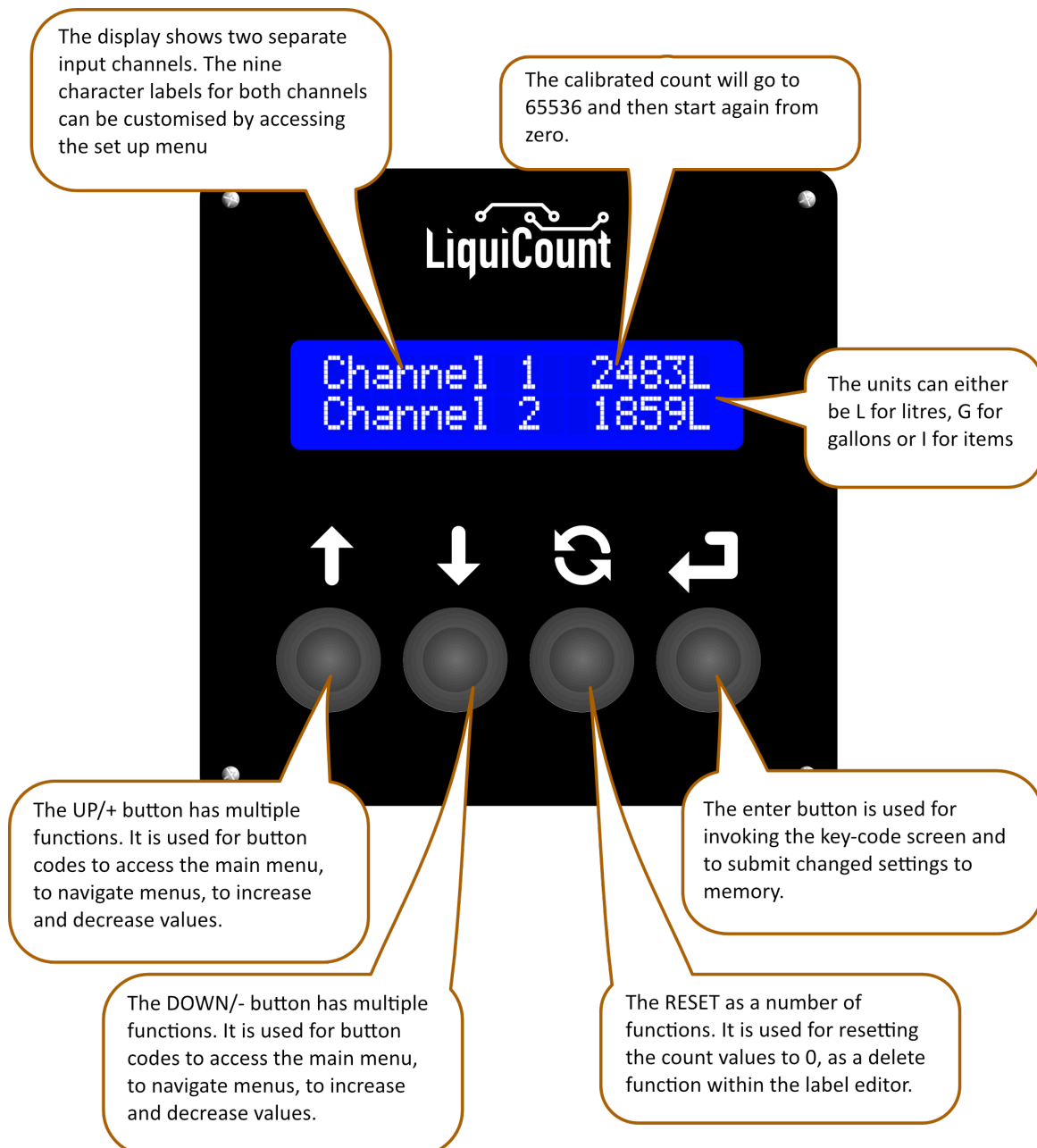

## 5. Technical Summary

- **Power Requirements:** 12-28V 0.25A
- **Inputs:** Channel 1 and channel 2 pulses
- **Output:** 100ms grounding pulses that correspond to defined units—making it compatible with external systems such as printers, loggers, or PLCs.
- **Display:** Channel 1 and channel 2 unit pulses in litres, gallons or items
- **Label length:** 9 characters per channel.
- **Data retention:** (totals, labels, K-factors, sensor voltage, unit selection).
- **Power-loss resilience:** on power-loss detection, current totals are written to memory to protect data.

## 6. Capabilities

- Two independent channels, each counted and displayed separately.
- Per-channel calibration (K-Factor): set pulses-per-unit to align counts with your flow sensor(s).
- Selectable units: litres, gallons or items (displayed as L/G/I) with the selection stored in memory.
- Clear, simple user interface: four buttons (UP, DOWN, RESET, ENTER) and a compact 16x2 LCD.
- Protected settings access: long-press ENTER from the Home screen to open a button-code gate before entering the Settings menu.
- Label customisation: assign up to a 9-character name to each channel (e.g., "WATER", "DETERGENT").
- Non-volatile storage: K-factors, labels, unit selection, and running totals are saved to memory.
- Built-in test tool: a "Generate Pulses" function to ensure that a printer, if connected, reads correctly.
- Housing: ABS enclosure
- Fits into a 92x92mm mounting hole
- Counter accuracy depends on correct K-Factor calibration and fluid conditions. Validate calibration during commissioning.

## 7. User Operation

### 7.1 Startup Procedure

1. When power is supplied to the LC1 counter. The display will show 'Booting...'
2. After 2.5 seconds, the splash screen will appear showing the software version.
3. The home screen will then appear, showing the channel labels and the total number of units delivered since the last reset. As pulses are received and converted to units, the units count will increase.

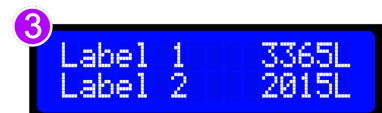
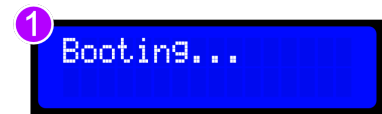

### 7.2 Resetting Counts

1. To reset the counts to zero, press the RESET button and the reset confirmation screen will appear.
2. Pressing the UP button cancels the reset and returns you to the home screen, displaying the current values.
3. To confirm the reset, press the ENTER button, which will return you to the home screen with zero counts.

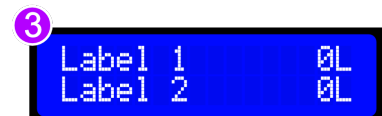
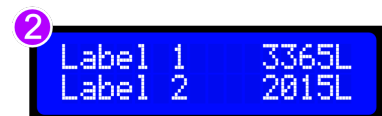

## 7.3 Access to Settings Menu

The Settings Menu offers access to five core configuration functions of the LiquiCount LC1 system: Calibration, Sensor Voltages, Test Pulses, Label Editing and Units. These functions are accessed via a protected menu, navigated using the physical buttons.

1. To access the settings menu, press the enter button for five seconds or until the 'ENTER CODE TO ACCESS SETTING' message is displayed. Press the 'UP' button three times and then the 'DOWN' button once.

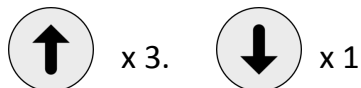

1  
ENTER CODE TO  
ACCESS SETTINGS

2  
RESET VALUES  
BEFORE ACCESS

3  
WRONG CODE  
ENTERED

4  
>CALIBRATE  
SENSOR VOLTAGE

2. Note: If the count is greater than zero, you will receive this message. Use the reset button to reset the values back to zero. (See 'Resetting Counts'). Once the counts have been reset you can try again.
3. If the combination is wrong a 'WRONG CODE ENTERED' message will be displayed.
4. When the correct sequence has been entered, the menu will appear

## 7.4 Main Menu Options

The main menu consists of five options. To navigate and cycle through the menu, use the UP and DOWN buttons. Select an option using the ENTER button. The screen only shows two rows at a time.

## 7.5 Calibration (CALIBRATE)

Calibration ensures the system correctly converts input pulses to litres, gallons or items.

1. To calibrate, select "Calibrate" from the main menu.
2. The display will show both Channel 1 K-Factor and Channel 2 K-Factor values which are the number of pulses per unit.
3. To edit the K Factor for a specific channel, select the channel and press ENTER. The display will indicate that it's now in edit mode, by moving the arrow to the right of the label.
4. The UP and DOWN buttons increase or decrease the K factor value. A single press of the up or down button changes the value by 0.1. Pressing and holding either up and down button will change the value faster.
5. When the required value is displayed, press the enter button to save it.
6. Once you've entered and saved your values, use the UP and DOWN buttons to scroll to the bottom of the menu. Pressing ENTER on the 'BACK' option will return you to the main menu.

1

```
>CALIBRATE
  SENSOR VOLTAGE
```

2

```
>CH1-KF      1.0
  CH2-KF      1.0
```

3

```
CH1-KF>      1.0
  CH2-KF      1.0
```

4

```
CH1-KF>      3.5
  CH2-KF      1.0
```

5

```
>CH1-KF      3.5
  CH2-KF      1.0
```

6

```
CH1-KF      3.5
>BACK
```

## 7.6 How to Calibrate

Note: If the LC1 is being used to count items, then no calibration is required other than to reset both K-factors to 1.

The K-factor for each channel changes how many pulses are counted per unit (G/L). By default, the K-factor for each channel is set to 1. Change the K-factor as required until the displayed count equals the delivered quantity. Deliver fluid into a calibrated container. If the display:

- Reads less than that delivered, decrease the K-factor.
- Reads more than that delivered, increases the K factor.

Continue to measure and compare until the display equals the delivered quantity.

**Note:** Any change to the fluid system may affect its accuracy. Re-check the calibration regularly

See the support section of the [liquicount.co.uk](http://liquicount.co.uk) website for more information on calibration.

## 7.7 Setting Sensor Voltages (SENSOR VOLTAGE)

Prior to use, you must ensure that the sensor voltage is correctly set for both channels. If the sensors in the system require 24 V, you will need to set them accordingly. If they require 5 V then you can start using it straight away as the default value for both channels is 5 V.

1. Select sensor voltage from the main menu.
2. The display will show both channels and the current voltage setting. Press the enter button to edit a channel.
3. Select the voltage sensor using the up-and-down buttons. The current sensor voltage selected is Indicated with 'ON' present for the chosen sensor voltage.
4. Confirm the sensor of voltage selected. To cancel the voltage sensor selected press the up button.

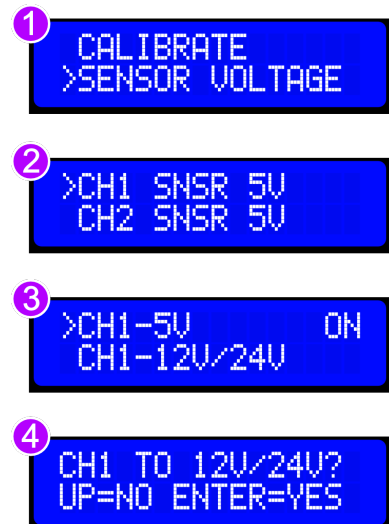

## 7.8 Test Pulses (GENERATE PULSES)

This function outputs 10 test pulses on each output channel to ensure that a printer, if connected, reads correctly.

1. Select generate pulses from the main menu.
2. The pulses will begin automatically, Ten pulses on channel one and then ten pulses on channel 2.
3. When both channels have completed the test pulses, you will be given the chance to run the test again.
4. Pressing the UP button will display the main menu. Pressing the ENTER button repeats the test pulses.

1  
SENSOR VOLTAGE  
>GENERATE PULSES

2  
10 CHANNEL 1 4Hz  
>

3  
10 CHANNEL 2 4Hz  
>

4  
RUN TEST AGAIN  
UP=NO ENTER=YES

## 7.9 Edit Labels (EDIT LABELS)

1. Select 'Edit Labels' from the main menu.
2. Similar to previous menus, use the UP and DOWN buttons to navigate. Press the ENTER button to select a channel.

①

```
GENERATE PULSES
>EDIT LABELS
```

3. To enter a character, use the UP and DOWN buttons to cycle through an alpha-numeric list of available characters.

②

```
>EDIT CH1 LABEL
EDIT CH2 LABEL
```

AaBbCcDdEeFfGgHhIjKkLlMmNn

OoPpQqRrSsTtUuVvWwXxYyZz 123456789-{BLANK SPACE}

When you've chosen the required character, press the ENTER key to move the cursor to the right to add the next character.

③

```
CH1 [ D      ]
      ^
```

4. Pressing the RESET button will backspace and remove characters. To start again, press the RESET button for three seconds, this will clear all entered characters and return the cursor to the beginning.

④

```
CH1 [      ]
      ^
```

5. To finish editing a channel label, keep pressing the ENTER key until the cursor reaches the end of the editable area. On the last ENTER press, the label will be saved, and the edit label menu will appear.

⑤

```
>EDIT CH1 LABEL
EDIT CH2 LABEL
```

6. To return to the main menu, cycle through the menu options to 'BACK' and select with the ENTER button.

⑥

```
EDIT CH1 LABEL
>BACK
```

## 7.10 Select Units to Display (UNITS)

On the homepage, after each value, a unit of measurement is displayed. For example, 'L' for LITRES, 'G' for GALLONS and I for ITEMS.

1. To set the unit of measurement, Select 'UNITS' from the main menu
2. Initially, the unit selected will be litres by default and will have 'ON' to the right of the unit to show this.
3. Use the UP and DOWN buttons to cycle through the four options available. LITRES, GALLONS and ITEMS and BACK
4. Select an option using the ENTER button. A screen will be displayed to confirm your selection.
5. Pressing the UP button cancels the process and displays the UNITS menu with no changes made. Pressing the ENTER button confirms the UNITS selected. The units screen will display 'ON' next to chosen unit.
6. To return to the main menu, cycle through the menu options to 'BACK' and select with the ENTER button.

1  
EDIT LABELS  
>UNITS

2  
>LITRES - L ON  
GALLONS - G

3  
>GALLONS - G  
ITEMS - I

4  
SET TO GALLONS?  
UP=NO ENTER=YES

5  
>GALLONS - G ON  
ITEMS - I

6  
>ITEMS - I  
BACK

## 7.11 Accrued Totals

The LC1 includes an Accrued Totals feature that records the total number of units delivered by each channel across multiple resets. This allows operators to track the lifetime quantity delivered without affecting the working totals displayed on the home screen.

Each time the main counter values are reset using the RESET button, the current totals are automatically added to the accrued totals before the display counters are cleared.

### Accessing Accrued Totals

1. From the main menu, scroll using the UP or DOWN buttons until ACCRUED TOTALS is displayed.
2. Press the ENTER button to open the accrued totals menu.

①  
UNITS  
>ACCRUED TOTALS

②  
>VIEW TOTALS  
RESET TOTALS

### Viewing Accrued Totals

1. In the ACCRUED TOTALS menu, select VIEW TOTALS and press ENTER.
2. The display will show the total accumulated units delivered for each channel. Press ENTER to return to the ACCRUED TOTALS menu.

①  
>VIEW TOTALS  
RESET TOTALS

②  
CH1: 1248L  
CH2: 1379L

### Resetting Accrued Totals

1. From the ACCRUED TOTALS menu, select RESET TOTALS and press ENTER.
2. The display will show the confirmation screen: Press UP to cancel and return to the ACCRUED TOTALS menu. Press ENTER to reset both accrued totals to zero.

①  
VIEW TOTALS  
>RESET TOTALS

②  
RESET TOTALS  
UP=NO ENTER=YES

### Important Notes

1. Accrued totals are only increased when the user performs a manual reset of the main counters or the main counters rollover.
2. Accrued totals are stored in non-volatile memory, so they are retained if power is removed.

---

## 7.12 Exit Menu (Return to Home Screen)

1. Selecting 'EXIT MENU' will return you to the home screen. All information entered, including calibration values, units, and labels, have been saved, so you can safely exit.



## 8. Safety Information

---

### 8.1 Intended Use

The LiquiCount LC1 is designed for monitoring and logging pulse-based measurement data in industrial and commercial environments.

The device is not intended for:

- Legal metrology applications
- Billing or trade measurement
- Safety-critical control systems
- Protective interlocking systems
- Use in explosive (ATEX) atmospheres
- Medical applications

Use of the product outside its intended purpose is the responsibility of the installer or end user.

---

### 8.2 Electrical Safety

The LC1 operates exclusively from a 12–28 V DC SELV (Safety Extra Low Voltage) supply.

⚠ The device must only be powered from a properly regulated SELV (Safety Extra Low Voltage) source.

- Do not connect to mains voltage.
- Do not connect to DC supplies exceeding 28 V.
- Do not connect to AC supplies.

Incorrect supply voltage may cause equipment damage and may invalidate conformity.

All signal inputs and outputs are SELV (Safety Extra Low Voltage)-level circuits only.

---

### 8.3 Installation Requirements

- Installation must be performed by competent personnel.
- The device is intended for fixed installation within a panel or enclosure.
- Ensure correct sensor supply voltage selection prior to connection.
- All wiring must comply with local electrical regulations.
- Do not over-tighten mounting screws.
- Disconnect power before wiring or servicing.

---

## 8.4 Mechanical Safety

The enclosure is designed for normal industrial handling.

- Do not subject the device to excessive mechanical shock.
- Do not strike or impact the enclosure.
- Do not use the enclosure as a structural support.

Mechanical robustness has been evaluated in accordance with EN 61010-1 requirements for accessible surfaces.

---

## 8.5 EMC Considerations

This equipment has been designed and tested in accordance with:

EN 61326-1 (EMC requirements for measurement, control and laboratory equipment)

To maintain EMC performance:

- Route sensor wiring separately from high-power conductors.
- Follow installation instructions.

---

## 8.6 FCC Compliance (United States)

For Class A Digital Devices:

This device complies with Part 15 of the FCC Rules. Operation is subject to the following two conditions:

1. This device may not cause harmful interference.
2. This device must accept any interference received, including interference that may cause undesired operation.

NOTE: This equipment has been tested and found to comply with the limits for a Class A digital device, pursuant to Part 15 of the FCC Rules. These limits are

## 8.6 ICES Compliance (Canada)

**English:** "This digital apparatus complies with CAN ICES-003(B)/NMB-003(B)."

**French:** "Le présent appareil numérique n'émet pas de bruits radioélectriques dépassant les limites applicables aux appareils numériques de Classe B prescrites dans le règlement sur le brouillage radioélectrique édicté par Innovation, Sciences et Développement économique Canada."

## 9. RoHS Declaration

This product complies with Directive 2011/65/EU (RoHS) as amended by (EU) 2015/863. Compliance has been demonstrated in accordance with EN IEC 63000, utilising supplier declarations and material assessments.

<b>Substances</b>	<b>Limit</b>
Lead (Pb)	0.1%
Cadmium (Cd)	0.01%
Mercury (Hg)	0.1%
Hexavalent Chromium (CR VI)	0.1%
Polybrominated biphenyls (PBBs)	0.1%
Polybrominated Diphenyl Ethers (PBDEs)	0.1%
Bis(2-ethylhexyl) Phthalate (DEHP)	0.1%
Benzyl Butyl Phthalate (BPP)	0.1%
Dibutyl Phthalate (DBP)	0.1%
Diisobutyl Phthalate (DIBP)	0.1%

## 10. Regulatory Compliance

This product has been designed and manufactured in accordance with applicable UK and EU legislation.

The CE and UKCA markings applied to the product indicate conformity with the relevant statutory requirements. The manufacturer holds the technical documentation required to demonstrate conformity and will make it available to market surveillance authorities upon request.

## 11. Measuring Instruments Directive (MID)

The LiquiCount LC1 is not designed or certified as a measuring instrument for legal metrology purposes.

The device is intended solely for monitoring and logging pulse-based measurement data. It is not approved for use in trade, billing, or other regulated measurement applications.

Use of data generated by the device for contractual or billing purposes is outside the intended use of the product.

## 12. Electrical & Environmental Classification

- Supply Voltage: 12–24 V DC (SELV (Safety Extra Low Voltage) only)
- Equipment Classification: Class III (SELV (Safety Extra Low Voltage) powered equipment)
- Overvoltage Category: I
- Operating temperature: 0 °C to +50 °C
- Storage temperature: –20 °C to +60 °C
- Relative humidity: <80% non-condensing
- Pollution Degree: 2
- Installation Category: I
- Maximum altitude: 2000 m
- Indoor use only

Operation outside these limits may impair protection.